

**NEWS RELEASE**

**TVR ENGINEERING Limited**  
Bristol Avenue  
Blackpool  
England FY2 0JF  
Telephone 0253-56151  
Fax 0253-57105  
Telex 67519

For further information  
contact: NOEL PALMER



**IMMEDIATE RELEASE  
OCTOBER 1988**

## **TVR AT THE BRITISH MOTOR SHOW STAND 320 OCTOBER 1988**

**TVR ENGINEERING LIMITED**, the sportscar manufacturers from Blackpool will be exhibiting a completely new range of vehicles on their stand at this years British International Motor Show at the NEC in Birmingham. The show will also feature updated models for the 1989 model year along with a special edition PENTHOUSE S model to announce their involvement in next years **TVR TUSCAN RACING**.

### **TVR S CONVERTIBLE – NEW FOR N.E.C. WITH 2.9 LITRE ENGINE.**

The S continues as the introductory TVR now fitted with the Ford 2.9 litre electronic fuel injected Vee6 engine. Thanks to TVR tubular manifolds and exhaust system, power is up to 168 bhp and torque to 172 lbs/ft. Revisions to pick up points on the rear suspension produce 10 per cent anti squat.

Price increases to £14,995.00 but now includes restyled dashboard and seats. Many more options, like wooden dashboard, electric windows and different design road wheels are available than before – reflecting the fact that many customers don't want a basic car.

**TVR S HARD TOP** – available for the first time on the S model is an easily removable hardtop. This is colour coded to match the paint of the vehicle and is designed to turn the convertible into a coupe. With a glass wrap around rear window designed to combat misting that occurs on convertible rear plastic screens, the hardtop is available as an aftermarket option or to be specified on a new car. A full length tonneau cover may be used to cover the interior when the hard or convertible top is fully removed. The hard top retails at £660.00.

### **TVR PENTHOUSE S – SPECIAL EDITION MODEL**

PENTHOUSE the International magazine for men join forces with TVR next year in the TUSCAN CHALLENGE. To celebrate this TVR are manufacturing a special edition of the S – The PENTHOUSE S.

The PENTHOUSE S is special in that it now comes fully equipped with many optional extras, not previously available on this model. These include the walnut dashboard, full leather trim, wilton carpets, electric windows, wooden steering wheel and gear lever knob, higher specification radio cassette player, mohair roof, tinted glass and discreet PENTHOUSE logos.

Penthouse are supplying six of their Pets for press and trade days at this year's NEC including Maria Whittaker and Suzi Mittzi for exclusive picture sessions on the cars.

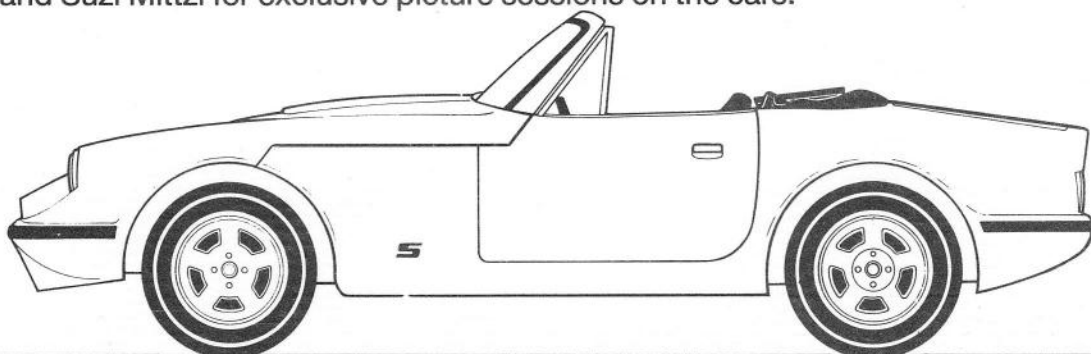

## **TVR 350i CONVERTIBLE – CONTINUES UNALTERED IN SPECIFICATION.**

**Price increases take 350i to £19,350.00**

## **TVR TUSCAN ROAD CAR – NEW VEHICLE TO BE LAUNCHED AT NEC**

The TUSCAN has been developed from the E.S. model the Company showed off at last years London Motorfair, where it was intended to be a higher performance version of the standard S Convertible. This was to use the new Australian Holden 3.8 litre Vee6 unit but production problems on the engine caused delays throughout this year. TVR have now completely re-engineered the car with a totally new chassis that gives 2 inches longer wheelbase and 4 inches wider track. Power will come from a TVR modified Rover 3.5 litre Vee8 that produces 225 bhp instead of the normal 197 bhp. This will give a suitable power to weight ratio to produce acceleration of 5 seconds to 60 mph and a top speed of 145 mph. Totally new bodyshell further separates the Tuscan from the S. Price to be approximately £20,000.00.

## **TVR TUSCAN RACER – LIMITED RUN OF 35 VEHICLES FOR NEXT YEARS TUSCAN CHALLENGE.**

A specially equipped race version of the TUSCAN will be on show for the Company's one make racing series next year. Organised in conjunction with the B.R.S.C.C. the series will run at 12 venues throughout the 1989 with some £35,000.00 prize money. All vehicles are already sold and will be produced next February when the factory will cease production of all other models to manufacturer the racers. All cars will be ready to race inclusive of all necessary race and safety equipment and power will be by a 320 bhp 4 litre version of the Vee8 engine. Extensive technical and financial back up from the factory is being made available to the competitors.

## **TVR 400 SE CONVERTIBLE – NEW FOR 1989 MODEL YEAR.**

An increase in piston diameter takes the 3905 cc TVR developed Vee8 engine to 4 litres for the 1989 model year cars to replace the 390 SE. Power output remains the same at 275 bhp but extensive restyling is made to the front and sides of the car. Integrated front bumpers, air dam and side skirts are all new with rectangular light units in revised pods. Price £24,995.00.

## **TVR 450 SE CONVERTIBLE – NEW FOR 1989 MODEL YEAR**

In addition to the 400 SE model is the 450 SE Convertible. This utilises the same bodystyle but a larger capacity engine. Here bore stroke ratio is increased from the old 4.2 litre TVR developed engine and the new powerplant now produces 320 bhp. Torque is increased to 300 ft/lbs. Acceleration is slightly increased to 4.7 seconds from zero to sixty miles per hour with a maximum speed in excess of 150 mph. Price of the 450 SE is £27,500.00.

## **TVR 450 S.E.A.C. CONVERTIBLE – NEW ENGINE FOR 1989.**

The 450 S.E.A.C. Kevlar and Carbon Fibre bodyshelled TVR will not be on display at the show as there are no body or specification alterations with the exception of the revised capacity engine. Orders currently in production take delivery up to May 1989 and customer specification is highly individualised. Price increases to £33,950.00.

## **OTHER INFORMATION**

TVR are now producing 15 vehicles per week and in the last two months took possession of two buildings next door to the Blackpool factory. This gives an additional floor space of 10,000 sq. ft. Plans are in hand to increase the workforce by 35 – 40 by the end of the year with production slowly rising to 20 vehicles per week. Sales/profit and manufacturing levels this year now equal that of Jaguar cars on a unit basis allowing the company to plan future activity on a longer term basis than ever before.

TVR recently took the step of obtaining retail outlet premises in Paris to increase the distribution of it's vehicles there and exhibited at the recent Paris Motor Show where sales interest was enormous.